

Capacidade de Carga - Load Capacity - Capacidad de carga

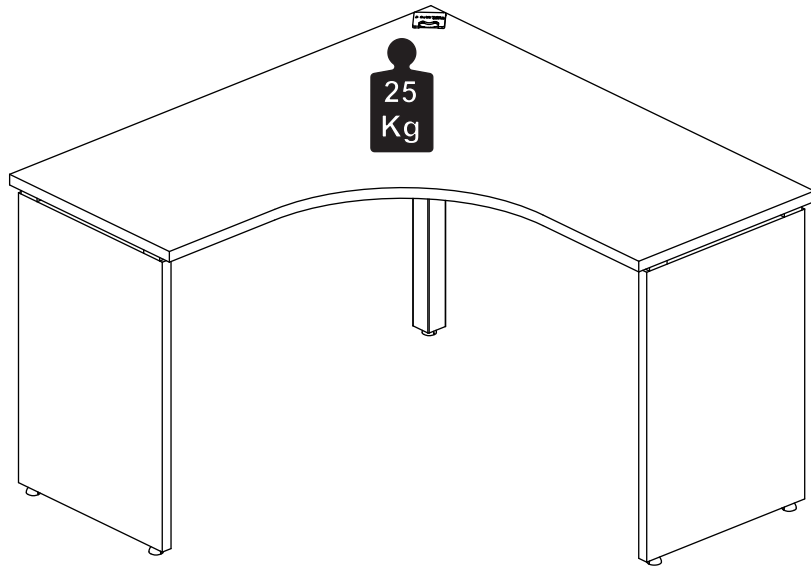

Manutenção e Limpeza

Vidros: pano levemente umedecido com álcool, seguido de pano seco.
Madeiras: pano levemente umedecido com água, seguido de pano seco.
*Nunca utilizar produtos químicos ou abrasivos.

Maintenance and Cleaning

Glasses: cloth lightly moistened with alcohol, followed by dry cloth.
Woods: cloth slightly moistened with water, followed by cloth seo.
*Never use chemicals or abrasives.

Mantenimiento y Limpieza

Vidrios: legeramente humedecido con alcohol, seguido de un paño seco.
Madera: ligeramente humedecido con agua, seguido de un paño seco.
*No utilice nunca productos quimicos o abrasivos.

08/08

INSTRUÇÕES DE MONTAGEM ASSEMBLY INSTRUCTIONS INSTRUCCIONES DE MONTAJE

MESAS TABLES TABLAS

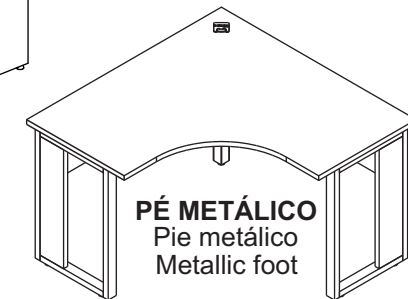
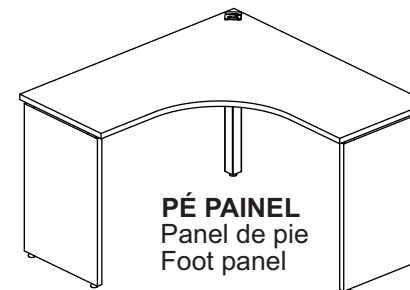

1 P.



8mm



30mm

REF. #EXP1219-1319-1519
REF. #EXP1220-1320-1520

 **Gebbwork**

MOBILIÁRIO
PARA ESCRITÓRIO

GEBB Work Ind. de Móveis Ltda.
Rua Felix Roman, 190
São Valentin

95709-170 - Bento Gonçalves - RS - Brasil
Fone: (0XX54) 3454-1105 - (0XX54) 3453-1407
Phone: (0XX54) 3454-1105 - (0XX54) 3453-1407
E-mail: pedidos@gebbwork.com.br
www.gebbwork.com.br
WhatsApp: +55 54 99177-8324

REV.: 01 - 11/05/2022

01/08

LISTA DE PEÇAS

- 01 - Painel Lateral Esquerdo
- 02 - Painel Lateral Direito
- 03 - Tampo
- 04 - Painel Frontal
- 05 - Tubo

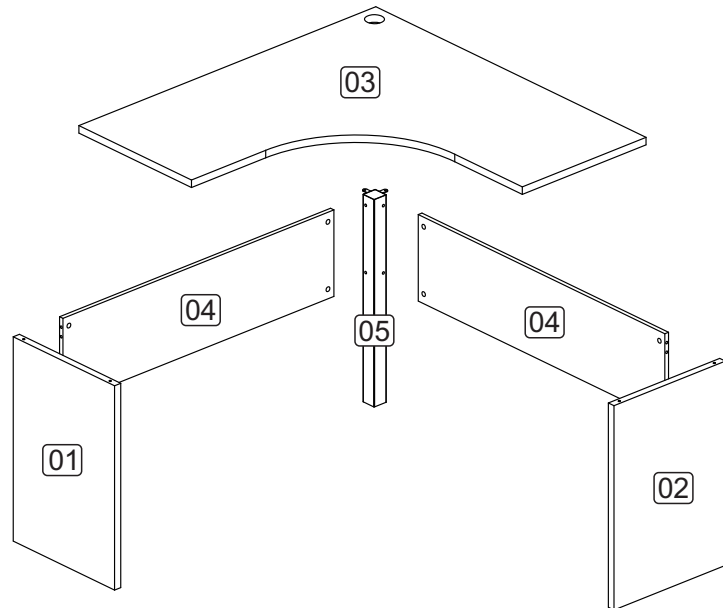

LISTA DE PIEZAS

- 01 - Panel Lateral Izquierda
- 02 - Panel Lateral Derecha
- 03 - Tapa
- 04 - Panel Delantero
- 05 - Tubo

PARTS IDENTIFICATION

- 01 - Left Side Panel
- 02 - Right Side Panel
- 03 - Top
- 04 - Panel Front
- 05 - Tube

4 Exclusivo do pé metálico (ver manual do pé metálico)

Exclusivo para pies metálicos (ver el manual del pie metálico)
Exclusive for metal feet (see metallic foot manual)

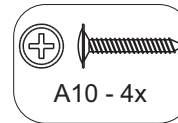
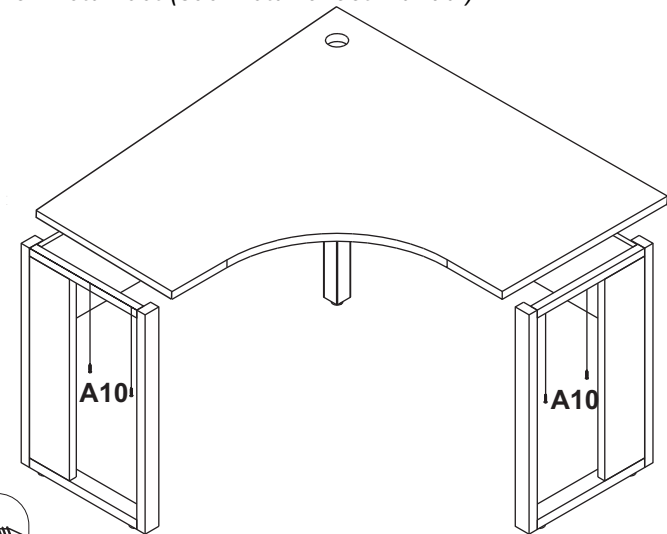

5

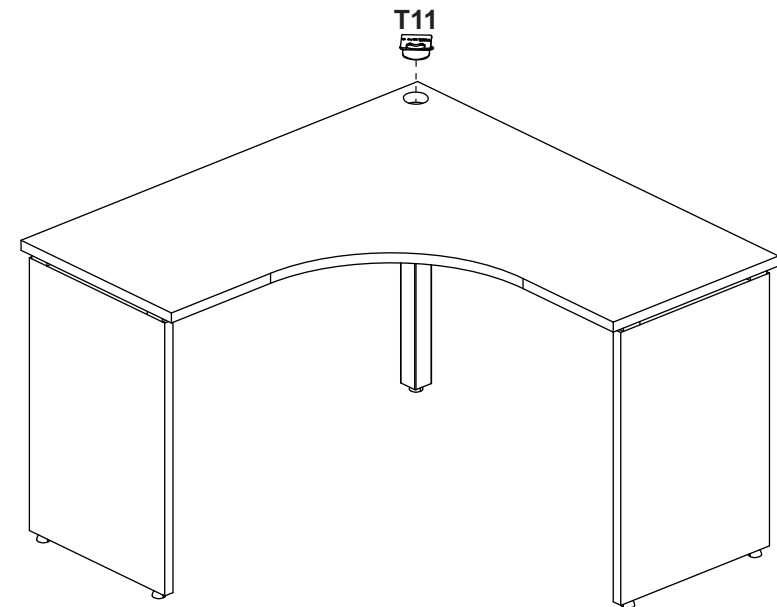

4 Exclusivo do pé painel

Exclusivo para panel de pie
Exclusive for foot panel

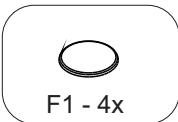
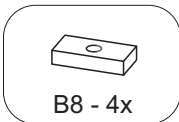
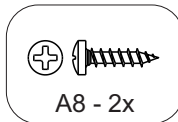
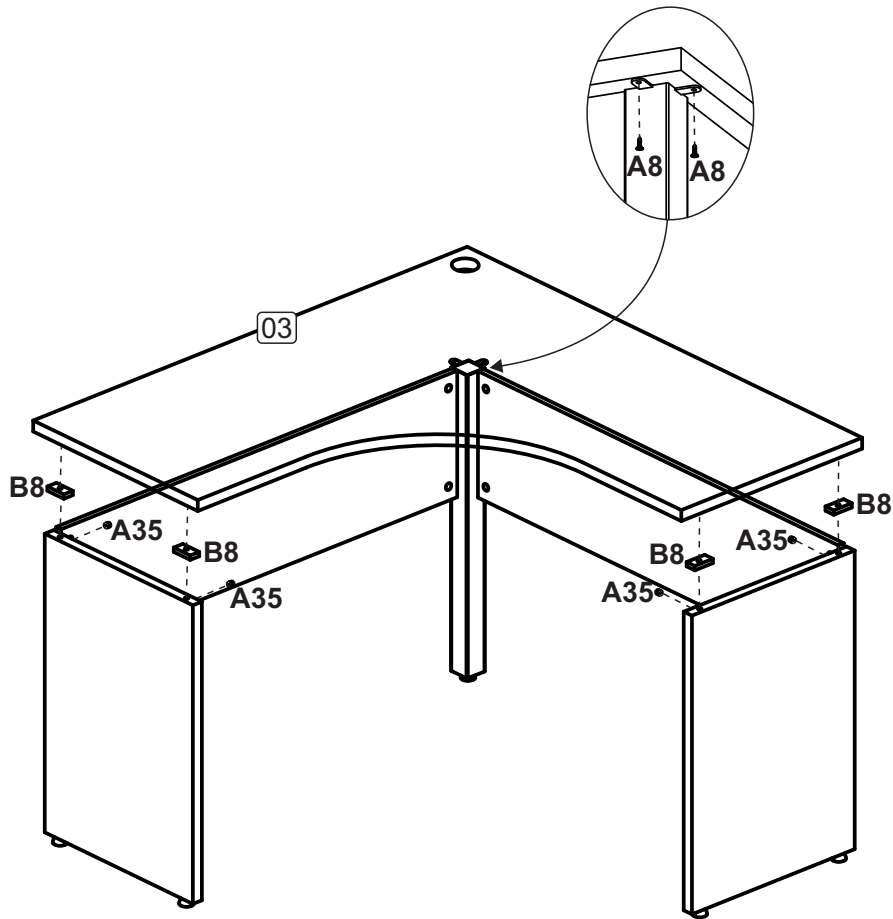

ACESSÓRIOS ACCESSORIES ACCESORIOS

A8 - PARAF. 4,0x14 CP
2x

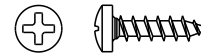

A29 - PARAF. MINIFIX
M6x33m 12x

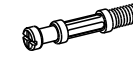

A35 - TAMBOR MINIFIX
12x



A36 - BUCHA M6x33
8x



B8 - DISTANCIADOR
50x24x10 4x



D1 - CAVILHA 8x30
4x

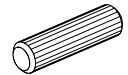

F1 - TAPA FURO ø18
12x



L2 - SAPATA PLAST. SEXT.
5x



L5 - BUCHA PLÁSTICA
P/SAPATA 5/16 4x



P11 - PONTEIRA 50X50
ROSCA 5/16 PRETO
1x



T11 - PASSA CABO GEBB
60MM 1x



P12 - PONTEIRA INT.
RETA 50x30mm 2x

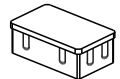

A10 - PARAF. 4,0x20 CF
4x



1 PRÉ-MONTAGEM

Preasamblea
Pre-assembly

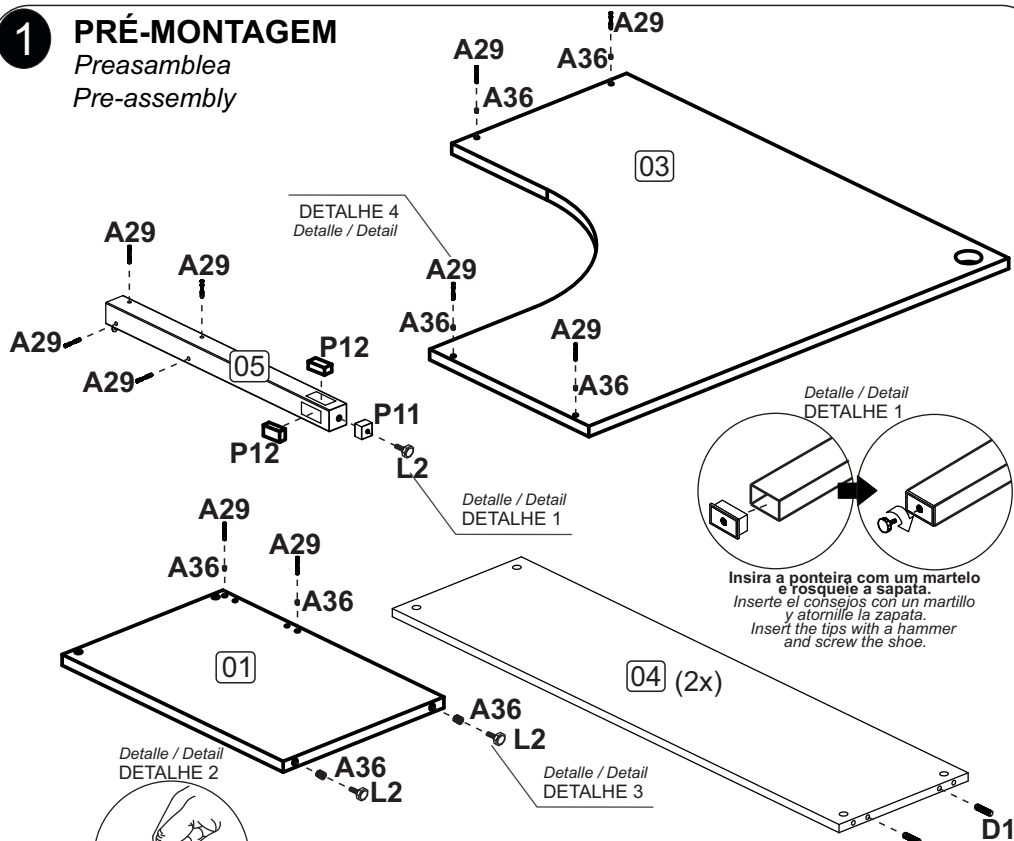



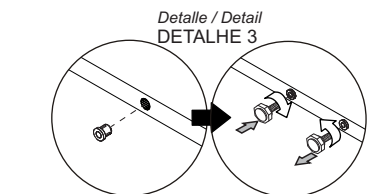

Pressione até o fundo do furo.
Se necessário utilize um martelo de borracha.
Presione hasta el fondo del agujero.
Si es necesario, utilice un mazo de goma.
Press to the bottom of the hole.
If necessary use a rubber mallet.



Insira a bucha com um martelo e rosqueie a sapata no sentido horário para baixar a altura final do móvel e, sentido anti-horário para aumentar a altura do móvel.
Inserte el portabrocas con un martillo y atornille la zapata en el sentido de las agujas del reloj para bajar la altura final del mueble y en el sentido contrario a las agujas del reloj para aumentar la altura del mueble.
Insert the chuck with a hammer and screw the shoe clockwise to lower the final height of the furniture and counterclockwise to increase the height of the furniture.

Com uma chave allen insira a bucha na peça, apos, rosqueie o parafuso.
Con una llave Allen, inserte el mandril en la pieza y luego atornille el tornillo.
Using an Allen key, insert the chuck into the part, then screw the screw.

-  P12 - 2x
-  A36 - 8x
-  D1 - 4x
-  L2 - 5x
-  L5 - 4x

2 MONTAGEM

Armado
Assembly

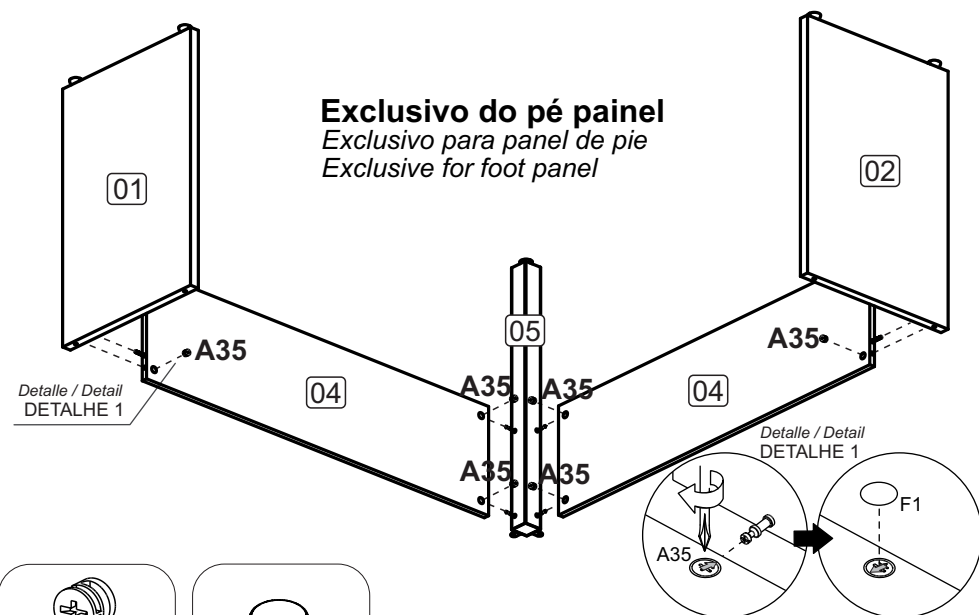

Exclusivo do pé painel
Exclusivo para panel de pie
Exclusive for foot panel

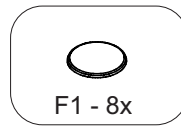
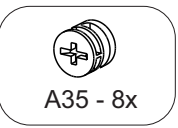

Depois de encaixar as peças coloque o tambor com a sua seta voltada para o parafuso. Para apertar Gire no sentido horário.
Después de colocar las piezas, coloque el tambor con su flecha hacia el tornillo. Para apretar, gire en sentido horario.
After fitting the parts, place the drum with its arrow facing the screw. To tighten, turn clockwise.

3 Exclusivo do pé metálico (ver manual do pé metálico)

Exclusivo para pies metálicos (ver el manual del pie metálico)
Exclusive for metal feet (see metallic foot manual)

