

Capacidade de Carga - Load Capacity - Capacidad de carga

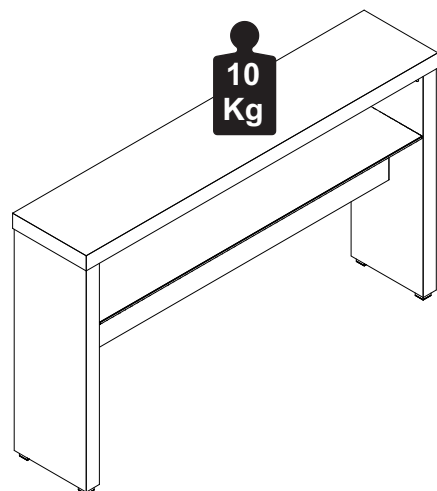

Manutenção e Limpeza

Vidros: pano levemente umedecido com álcool, seguido de pano seco.
Madeiras: pano levemente umedecido com água, seguido de pano seco.
*Nunca utilizar produtos químicos ou abrasivos.

Maintenance and Cleaning

Glasses: cloth lightly moistened with alcohol, followed by dry cloth.
Woods: cloth slightly moistened with water, followed by cloth seo.
*Never use chemicals or abrasives.

Mantenimiento y Limpieza

Vidrios: legeramente humedecido con alcohol, seguido de un paño seco.
Madera: ligeramente humedecido con agua, seguido de un paño seco.
*No utilice nunca productos quimicos o abrasivos.

INSTRUÇÕES DE MONTAGEM ASSEMBLY INSTRUCTIONS INSTRUCCIONES DE MONTAJE

APARADOR SIDEBOARD APARADOR

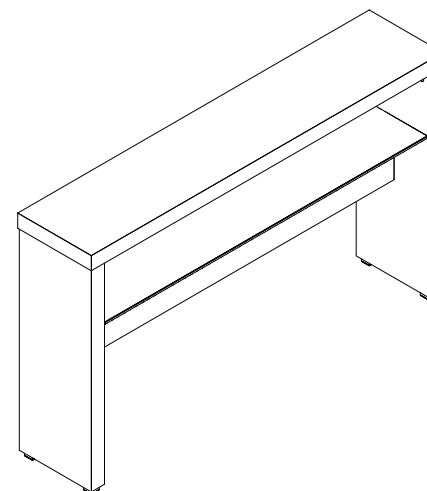

REF. #EDG1330



MOBILIÁRIO
PARA ESCRITÓRIO
GEBB Work Ind. de Móveis Ltda.
Rua Felix Roman, 190
São Valentin

95709-170 - Bento Gonçalves - RS - Brasil
Fone: (0XX54) 3454-1105 - (0XX54) 3453-1407
Phone: (0XX54) 3454-1105 - (0XX54) 3453-1407
E-mail: pedidos@gebbwork.com.br
www.gebbwork.com.br
WhatsApp: +55 54 99177-8324



1 P.



8mm



20mm

LISTA DE PEÇAS

- 01 - Painel Lateral
- 02 - Tampo
- 03 - Prateleira de Vidro
- 04 - Painel Frontal

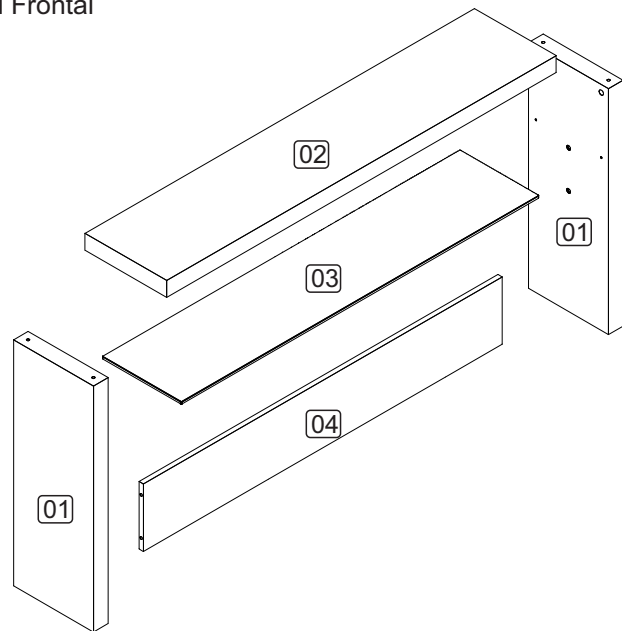

LISTA DE PIEZAS

- 01 - Panel Lateral
- 02 - Tapa
- 03 - Estante de Vidro
- 04 - Panel Delantero

PARTS IDENTIFICATION

- 01 - Panel Side
- 02 - Top
- 03 - Glass Shelf
- 04 - Front Panel

ENCAIXE A PRATELEIRA DE VIDRO NOS SUPORTES

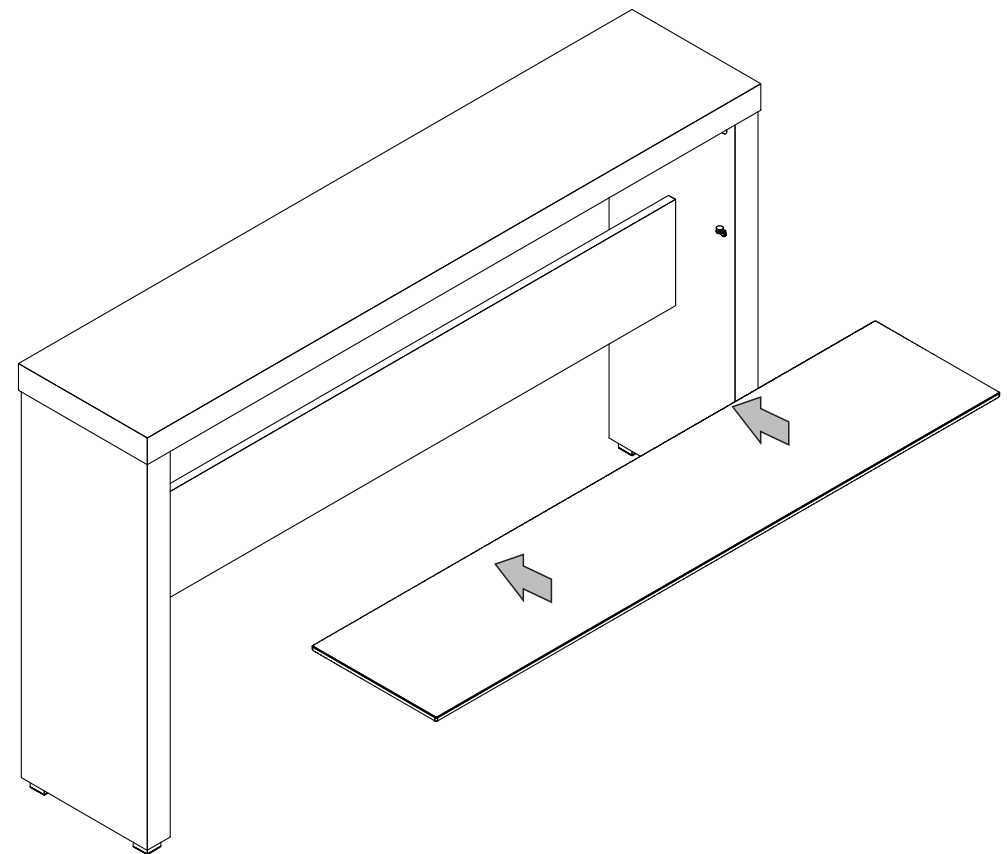

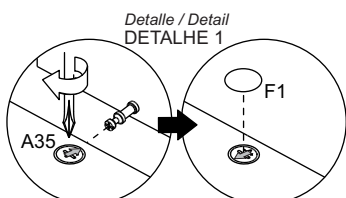
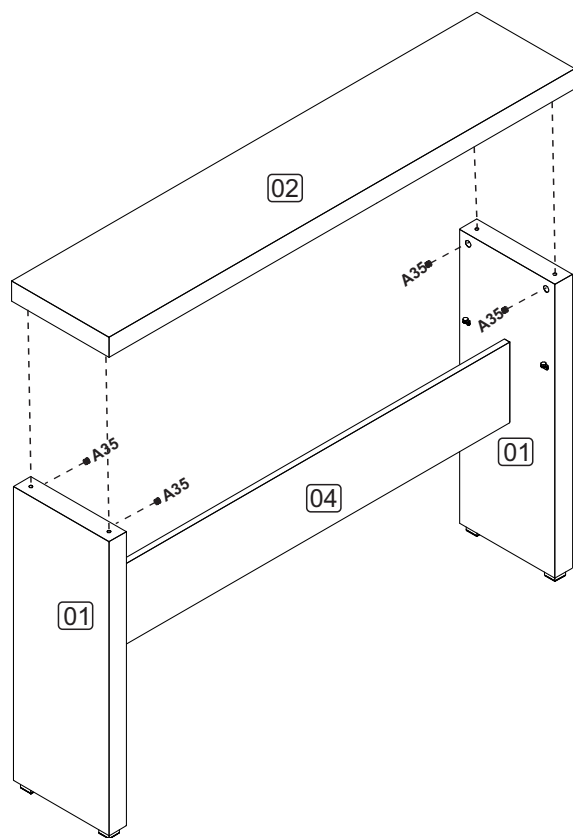
3

Depois de encaixar as peças coloque o tambor com a sua seta voltada para o parafuso. Para apertar Gire no sentido horário.
 Después de colocar las piezas, coloque el tambor con su flecha hacia el tornillo. Para apretar, gire en sentido horario.
 After fitting the parts, place the drum with its arrow facing the screw. To tighten, turn clockwise.

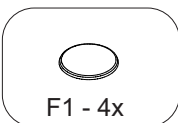
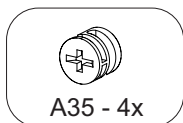

ACESSÓRIOS ACCESSORIES ACCESORIOS

F4 - BATENTE SILICONE
ø15MM **2x**



A29 - PARAF. MINIFIX
M6x33m **8x**

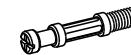

A35 - TAMBOR
MINIFIX **8x**



A36 - BUCHA M6x33
12x



B29 - SUPORTE PRATELEIRA.
ZAMAQ C/VNTOSA 331X6mm



F1 - TAPA FURO ø18
04x



L7 - SAPATA EM ALUMÍNIO
30x30x20mm **4x**



1 PRÉ-MONTAGEM

Preasamblea
Pre-assembly

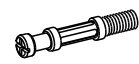
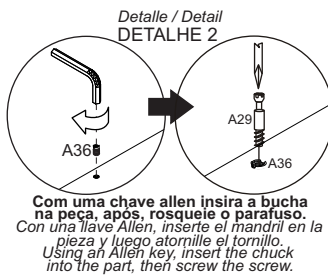
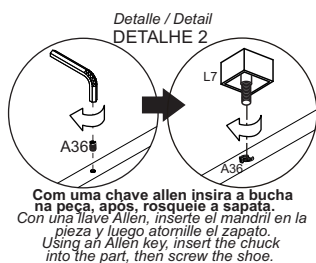
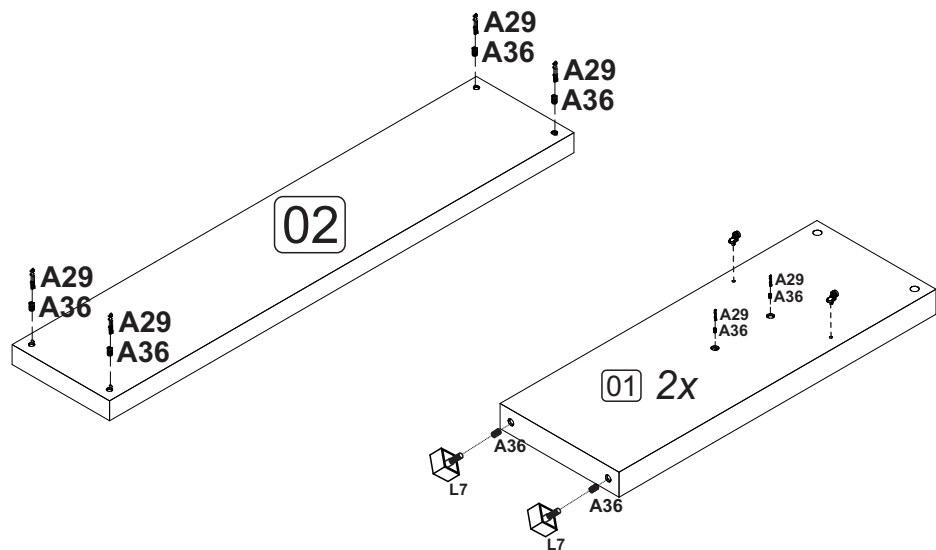

A29 - 8x



A36 - 12x



L7 - 4x

04/08

2 MONTAGEM

Armado
Assembly

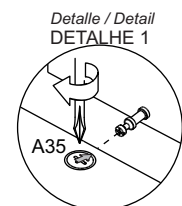
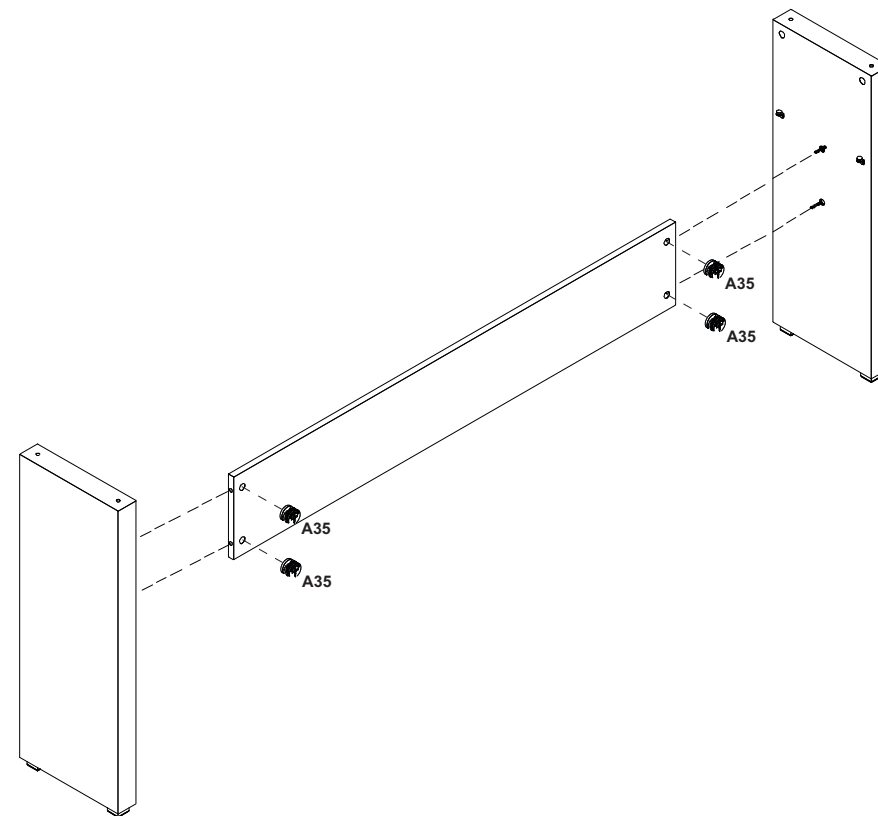

Depois de encaixar as peças coloque o tambor com a sua seta voltada para o parafuso. Para apertar Gire no sentido horário.
Después de colocar las piezas, coloque el tambor con su flecha hacia el tornillo. Para apretar, gire en sentido horario.
After fitting the parts, place the drum with its arrow facing the screw.
To tighten, turn clockwise.



A35 - 4x

05/08