

FRQ9591

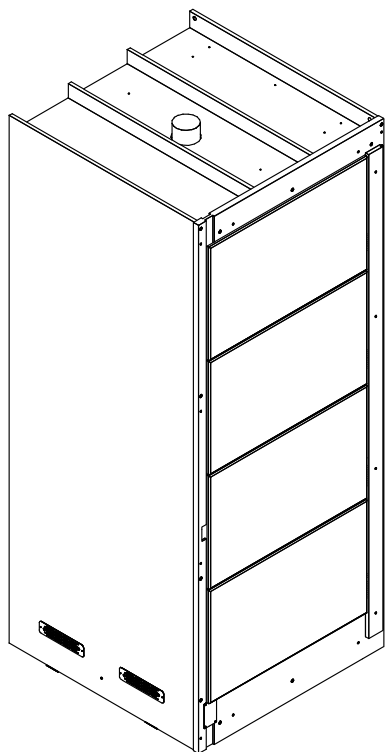

FRQ9593

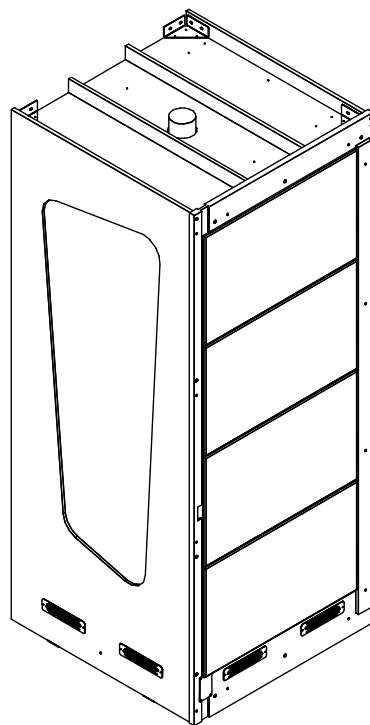

Manutenção e Limpeza

Vidros: pano levemente umedecido com álcool, seguido de pano seco.
Madeiras: pano levemente umedecido com água, seguido de pano seco.
*Nunca utilizar produtos químicos ou abrasivos.

Maintenance and Cleaning

Glasses: cloth lightly moistened with alcohol, followed by dry cloth.
Woods: cloth slightly moistened with water, followed by cloth seco.
*Never use chemicals or abrasives.

Mantenimiento y Limpieza

Vidrios: legeramente humedecido con alcohol, seguido de un paño seco.
Madera: ligeramente humedecido con agua, seguido de un paño seco.
*No utilice nunca productos químicos o abrasivos.

INSTRUÇÕES DE MONTAGEM ASSEMBLY INSTRUCTIONS INSTRUCCIONES DE MONTAJE

CABINE ACÚSTICA ACOPLAR 1 LUGAR
CABINA ACÚSTICA PAREJA 1 PLAZA
COUPLE ACOUSTIC BOOTH 1 PLACE

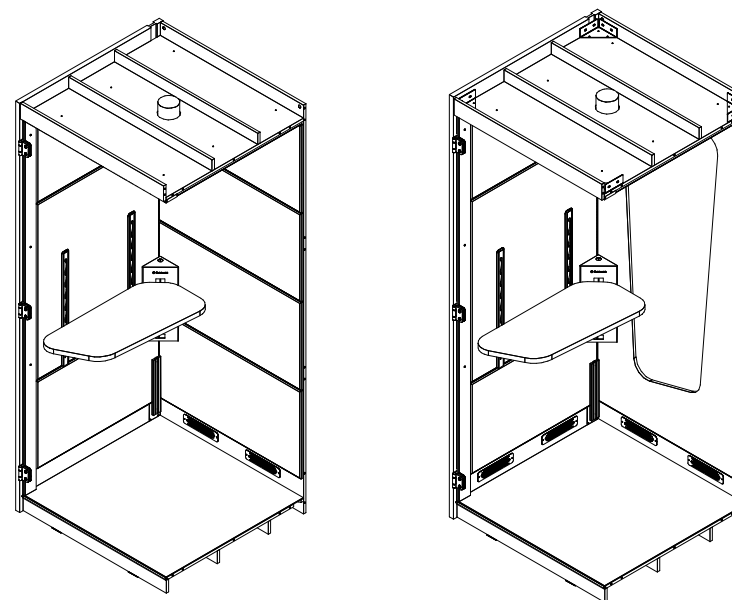

2 P.



6mm

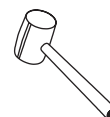

150mim

REF. #FRQ9591-9593



MOBILIÁRIO

PARA ESCRITÓRIO

GEBB Work Ind. de Móveis Ltda.

Rua Felix Roman, 190

São Valentin

95709-170 - Bento Gonçalves - RS - Brasil

Fone: (0XX54) 3454-1105 - (0XX54) 3453-1407

Phone: (0XX54) 3454-1105 - (0XX54) 3453-1407

E-mail: pedidos@gebbwork.com.br

www.gebbwork.com.br

WhatsApp: +55 54 99177-8324

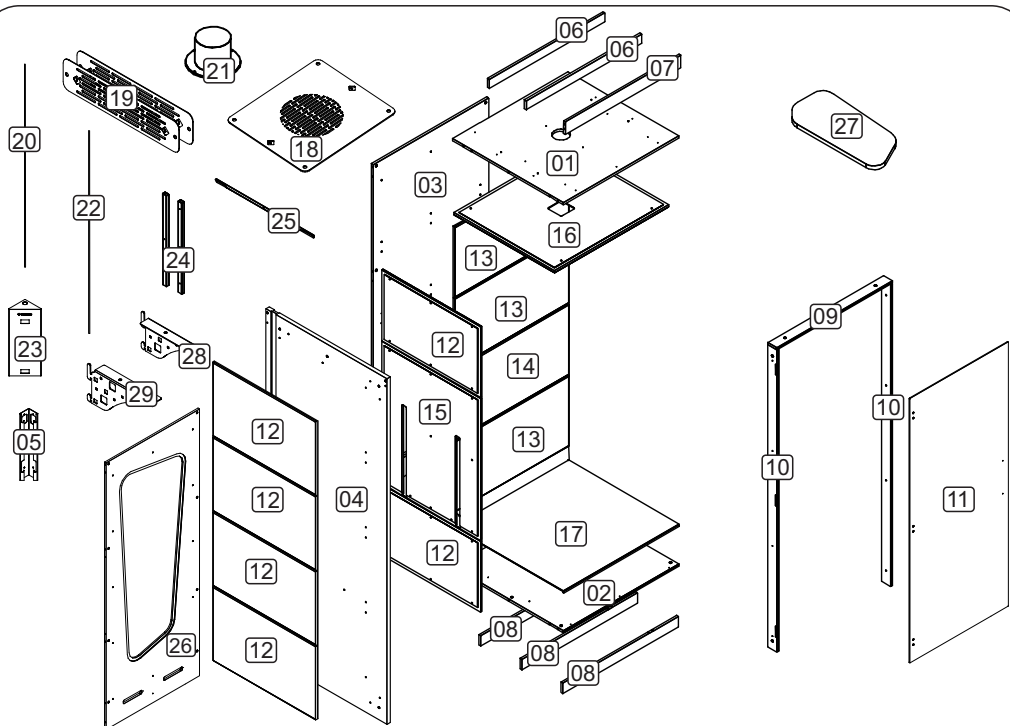

LISTA DE PEÇAS

- 01 - Tampo
- 02 - Base
- 03 - Costa
- 04 - Divisória
- 05 - Suporte Para Tomadas
- 06 - Travessa Superior
- 07 - Travessa Superior Maior
- 08 - Rodapé
- 09 - Travessa Superior Porta
- 10 - Travessa Lateral
- 11 - Porta Vidro
- 12 - Placa Estofada Lateral
- 13 - Placa Estofada Costa
- 14 - Placa Estofada Costa Recorte
- 15 - Placa Estofada lateral Recorte
- 16 - Placa Estofada Superior
- 17 - Carpete
- 18 - Tampa Acabamento Exaustor
- 19 - Chapa Entrada de ar
- 20 - Perfil Batente meia lua 10MM
- 21 - Exaustor
- 22 - Escova Adesiva para Vedação
- 23 - Suporte Traseiro Tomadas
- 24 - Cremalheira
- 25 - Cantoneira Suporte LED
- 26 - Costa com Vidro
- 27 - Tampo Mesa
- 28 - Mão francesa Direita
- 29 - Mão francesa Esquerda

LISTA DE PIEZAS

- 01 - Cubrir
- 02 - Base
- 03 - Costa
- 04 - Divisor
- 05 - Soporte de enchufe
- 06 - Travesía Superior
- 07 - Travesía Superior más grande
- 08 - Zócalo
- 09 - Travesía de la puerta superior
- 10 - Travesía de lado
- 11 - Puerta de cristal
- 12 - Tablero tapizado lateral
- 13 - Tablero tapizado Costa
- 14 - Tablero tapizado Costa Cutout
- 15 - Placa Estofada lateral Recorte
- 16 - Tablero tapizado superior
- 17 - Alfombra
- 18 - Cubierta de acabado de escape
- 19 - Placa de entrada de aire
- 20 - Perfil tope media luna 10MM
- 21 - Extractor
- 22 - Cepillo adhesivo para sellar
- 23 - Zócalos de soporte trasero
- 24 - Estante
- 25 - Soporte LED de esquina
- 26 - Costa con Vidrio
- 27 - Cubrir Mesa
- 28 - Mano derecha francesa
- 29 - Mano francesa izquierda

PARTS IDENTIFICATION

- 01 - Top
- 02 - Base
- 03 - Left
- 04 - Divider
- 05 - Socket Support
- 06 - Upper beam
- 07 - Larger Top Crossbeam
- 08 - Baseboard
- 09 - Upper Door Traverse
- 10 - Side Sleeper
- 11 - Glass Door
- 12 - Side Upholstered Board
- 13 - Costa Upholstered Board
- 14 - Costa Cutout Upholstered Plate
- 15 - Placa Estofada lateral Recorte
- 16 - Top Upholstered Board
- 17 - Carpet
- 18 - Exhaust Finishing Cover
- 19 - Air inlet plate
- 20 - Half moon stop profile 10MM
- 21 - Exhaust
- 22 - Adhesive Brush for Sealing
- 23 - Rear Support Sockets
- 24 - Rack
- 25 - Corner LED Support
- 26 - Coast with Glass
- 27 - Table Top
- 28 - Right French Hand
- 29 - Left French Hand

14 MONTAGEM

Armado Assembly

Encaixe a Cantoneira B31 na porta 12.

Coloque el ángulo B31 en el puerto 12.

Fit the Angle B31 on port 12.

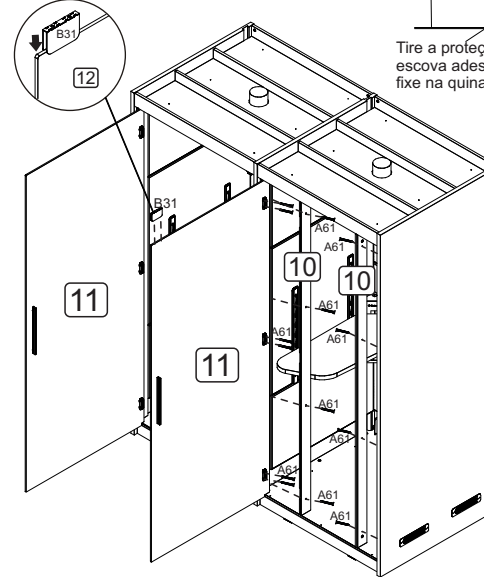

Tire a proteção da escova adesiva 22 e fixe na quina da porta 11.

Posicione as dobradiças G10 (já com as portas instaladas) sobre as marcações das laterais 04 e 05. Depois parafuse usando o parafuso A61.

Coloque las bisagras G10 (ya con las puertas instaladas) en el marcas en los lados 04 y 05. Luego atornillar con el tornillo A61.

Position the G10 hinges (already with the installed doors) on the markings on sides 04 and 05. Then screw using screw A61.

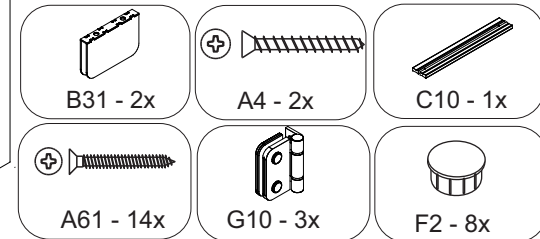

15 MONTAGEM

Armado Assembly

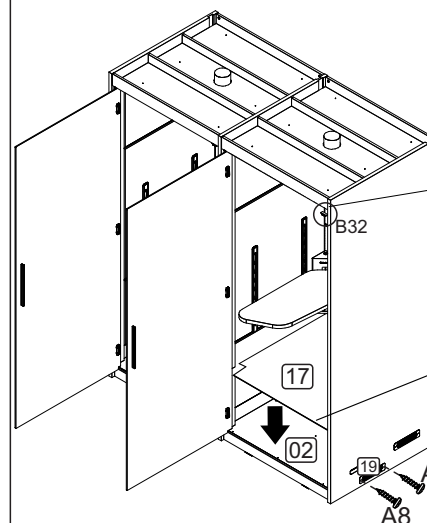

Recorte com um estilete o lado do carpete nas medidas indicadas ao lado.

Recortar con un cuchillo artesanal el lado de la alfombra en medidas indicadas al lado.

Cut out with a craft knife the carpet side in measurements indicated alongside.

Retire a proteção do adesivo carpete 17, em seguida fixe na base 02.

Retire la protección de la alfombra 17 entonces arreglarlo en la base 02.

Remove the protection from the carpet 17 then fix it on base 02.

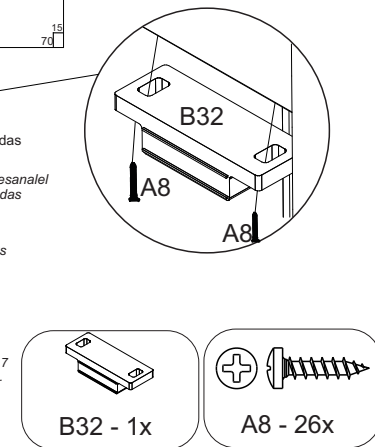

13 MONTAGEM

Armado
Assembly

Lado Direito

Lado Esquerdo

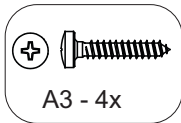
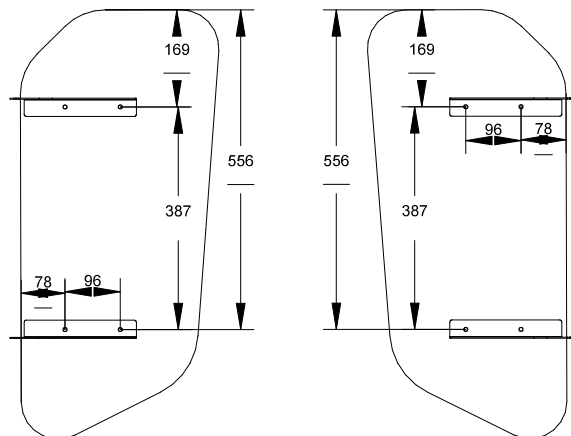

- 1° Identificar o lado que vai utilizar a mesa.
- 2° Com uso de uma trena e um lapis, fazer a marcação conforme cotas do desenho acima.
- 3° Fixe as mãos francesas com o parafuso A3 sobre a marcação feita anteriormente.

Encaixe o tampo 27 na cremalheira já fixada na lateral.

Coloque la tapa 27 en el rejilla ya fijada a un lado.
Fit the cover 27 into the rack already fixed to the side.

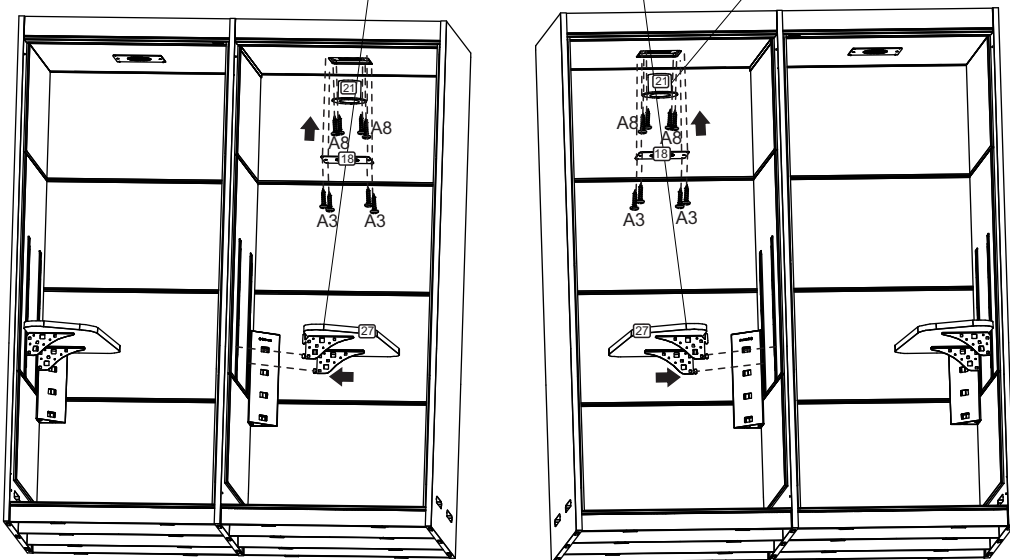

ACESSÓRIOS ACCESSORIES ACCESORIOS

D1 - CAVILHA 8x30
28x

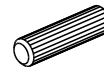

B33 - TAMPA FIAÇÃO
2x



M17 - CANTONEIRA L
4 FUROS 34x34MM 8x

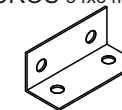

D9 - PINO SAPATA
MAGIC PRETO
81x



A8 - PARAF. 4,0x14 CP
34x



A6 - PARAF. 3,5x40 CC
16x



A61 - PARAF. 5,0x25 CC
48x



A36 - BUCHA M6x13
22x



A35 - TAMBOR
MINIFIX 22x



A29 - PARAF. MINIFIX
M6x33m 22x

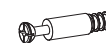

T11 - PASSA CABO GEBB
60MM 1x



F2 - TAPA FURO ø8
13x



G10- DOBRADIÇA VIDRO
3x



L13 - SAPATA DESLIZADORA
15X60MM 14x

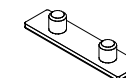

C10 - PUXADOR
ALEXANDRIA 1x



B31 - CANTONEIRA P/ VIDRO
2x



B32 - FECHO MAGNÉTICO
1x

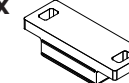

A4 - PARAF. 3,5x25 CC
2x



A44 - PARAF. M6x16 CP
4x

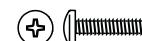

A3 - PARAF. 3,5x20 CP
4x



1 PRÉ-MONTAGEM

Preasamblea
Pre-assembly

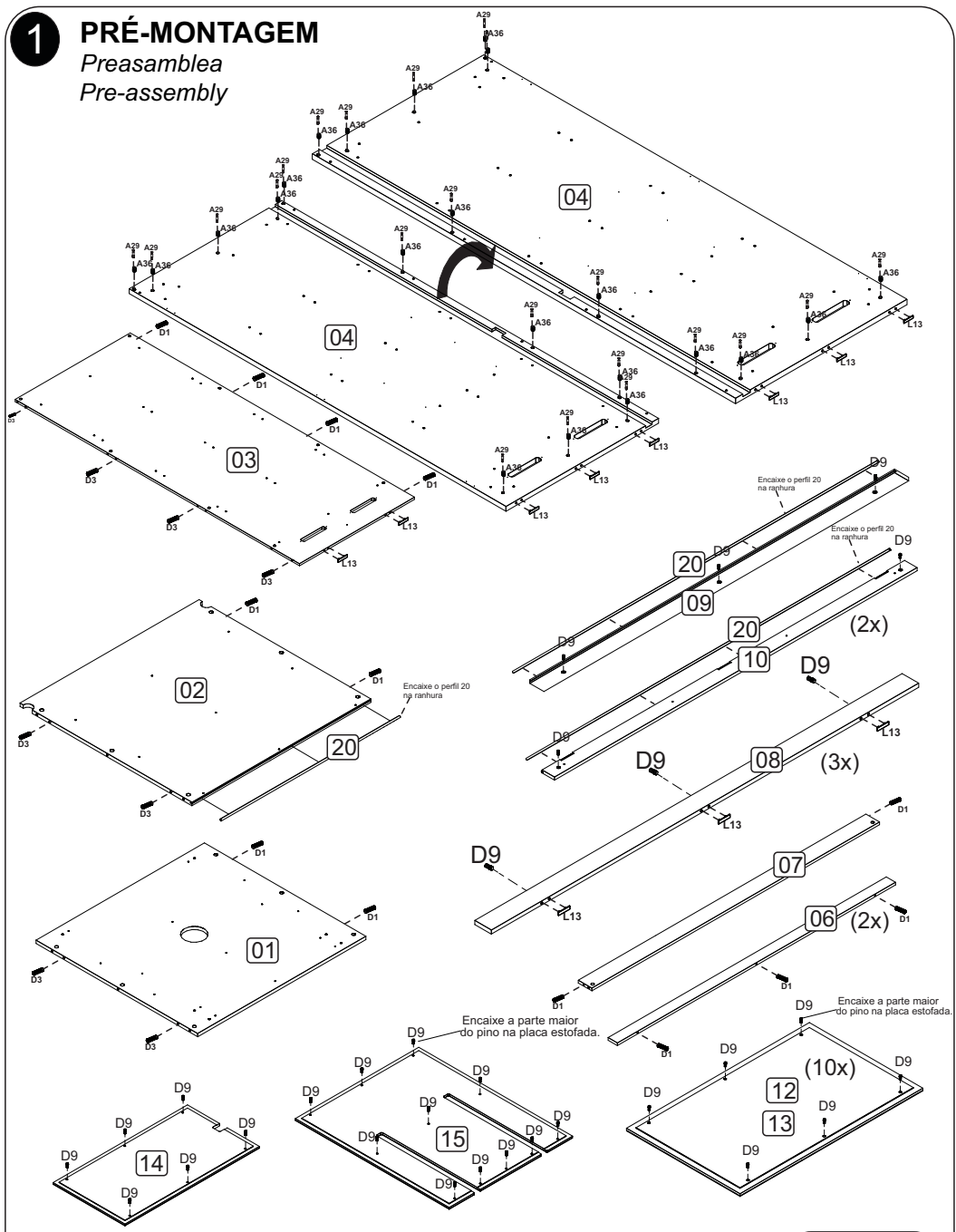





Encaixe o perfil 20 na ranhura.

Encaixe o perfil 20 na ranhura.

Encaixe a parte maior do pino na placa estofada.

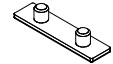
Encaixe a parte maior do pino na placa estofada.

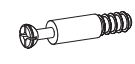
- 
D9 - 81x
- 
D1 - 28x
- 
L13 - 14x
- 
A36 - 22x
- 
A29 - 22x



11 MONTAGEM

Armado
Assembly

Lado esquerdo

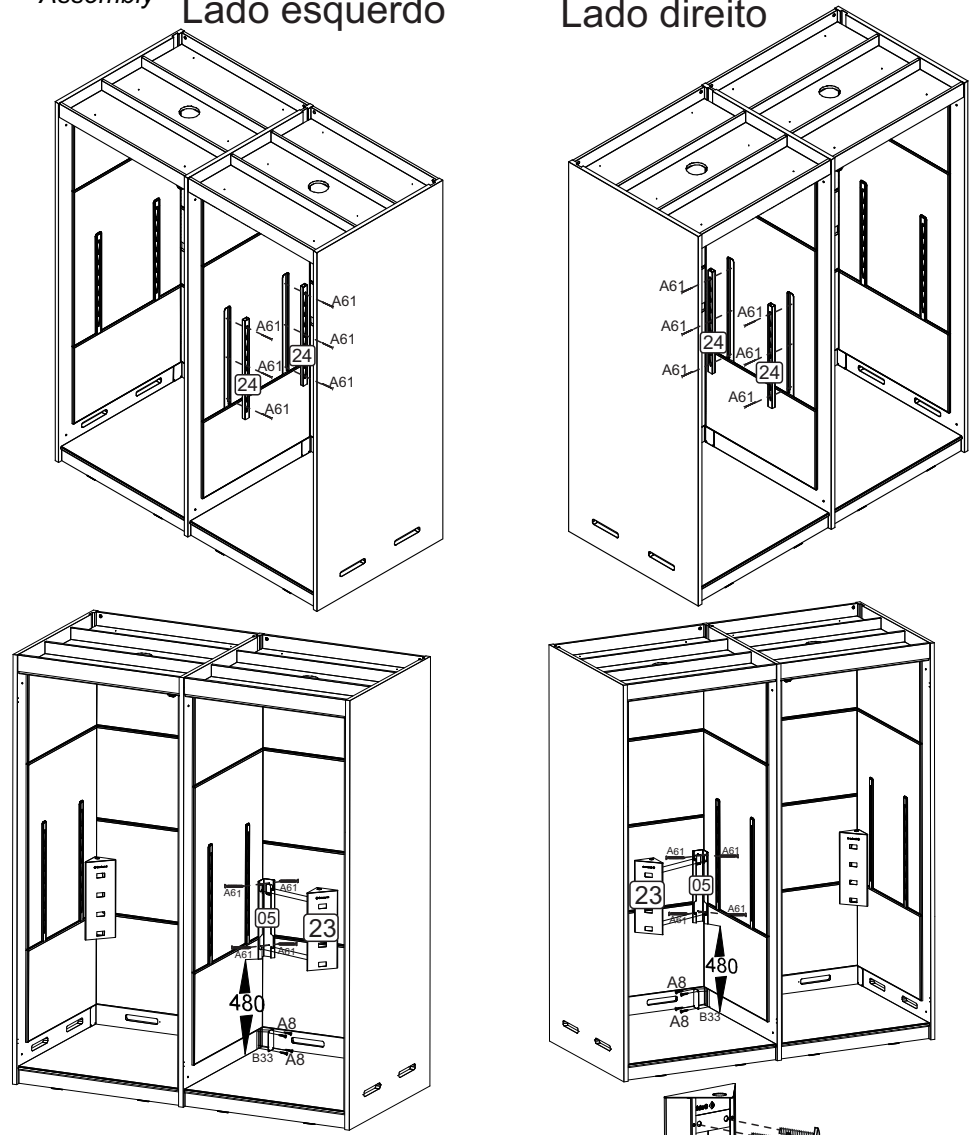
Lado direito

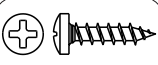

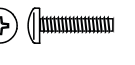
- 
A8 - 26x
- 
B33 - 2x
- 
A61 - 10x
- 
A44 - 4x

Encaixe os parafusos A44 nos furos. Rosqueie apenas a metade para poder encaixar no suporte tomadas 30

9 MONTAGEM

Armado
Assembly

Encaixe as placas 13 e 14 nas laterais 04 e 05.

Montar las placas 13 y 14 en los lados 04 y 05.

Fit the plates 13 and 14 on sides 04 and 05.

Posição da mesa lado, esquerdo, fixar a chapa 14 lado esquerdo.

Posición de la mesa auxiliar, izquierda, arreglar la placa y 14 lado izquierdo.

Side table position, left, fix the plate and 14 left side.

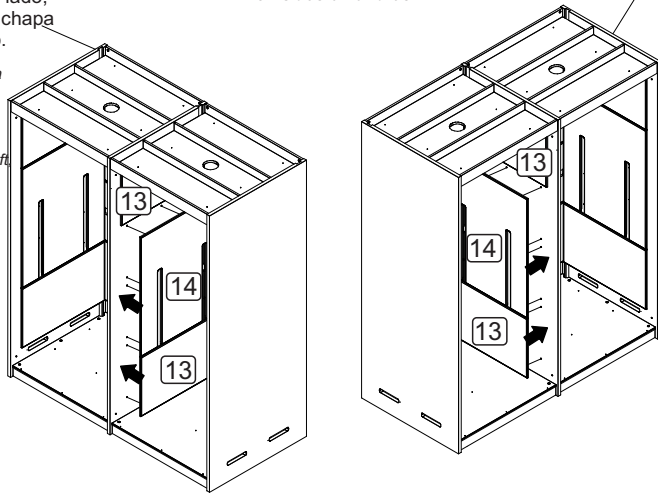

Posição da mesa lado, direito, fixar a chapa 14 lado direito.

Posición de la mesa auxiliar, recto, arreglar la placa 14 lado derecho.

Side table position, straight, fix the plate and 14 right side.

10 MONTAGEM

Armado
Assembly

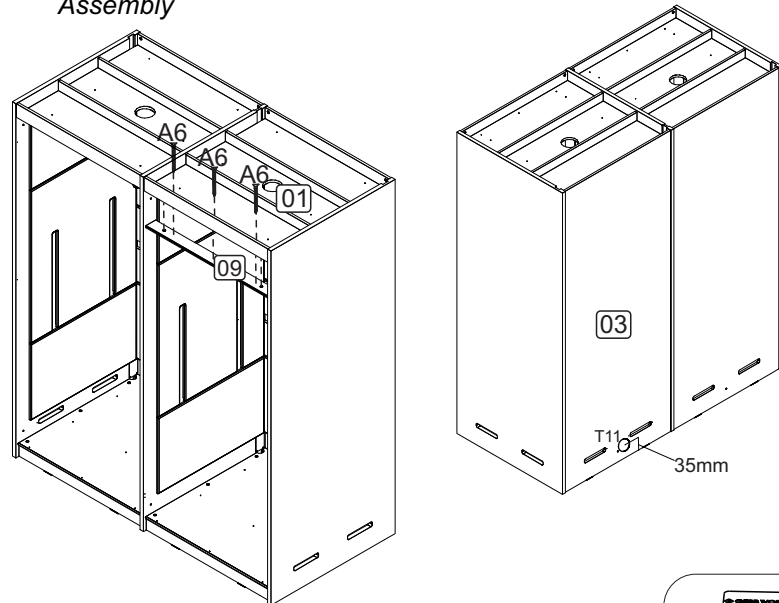

Fazer furo para passa-cabos na posição de necessidade entre costas ou laterais. A altura deve ser de 35mm até o centro do furo. Furo de diâmetro 60.

08/12



T11 - 1x



A61 - 3x

2 MONTAGEM

Armado
Assembly

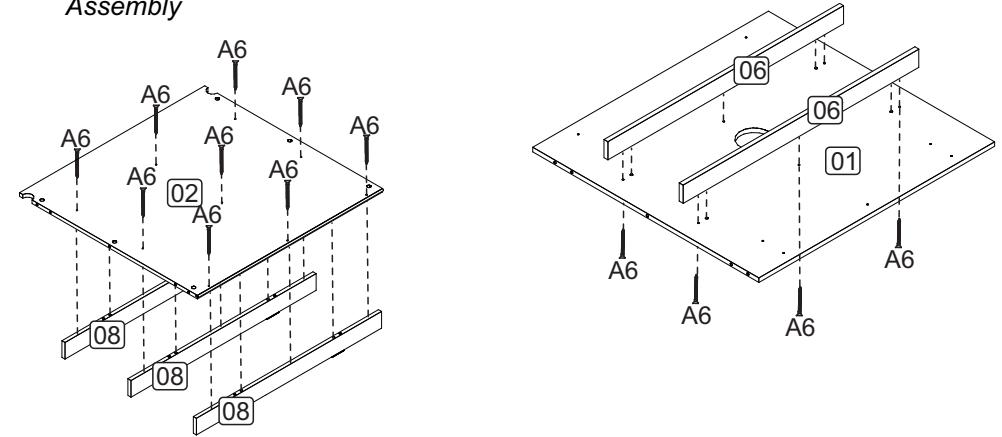

A6 - 15x

3 MONTAGEM

Armado
Assembly

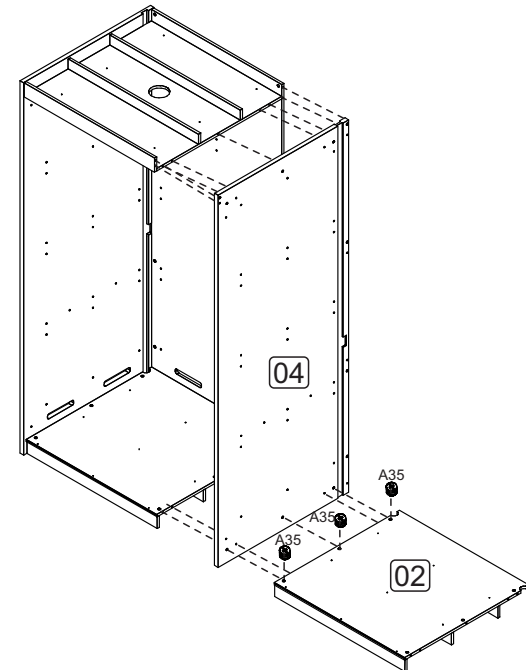

A35 - 3x

05/12

4 MONTAGEM

Armado
Assembly

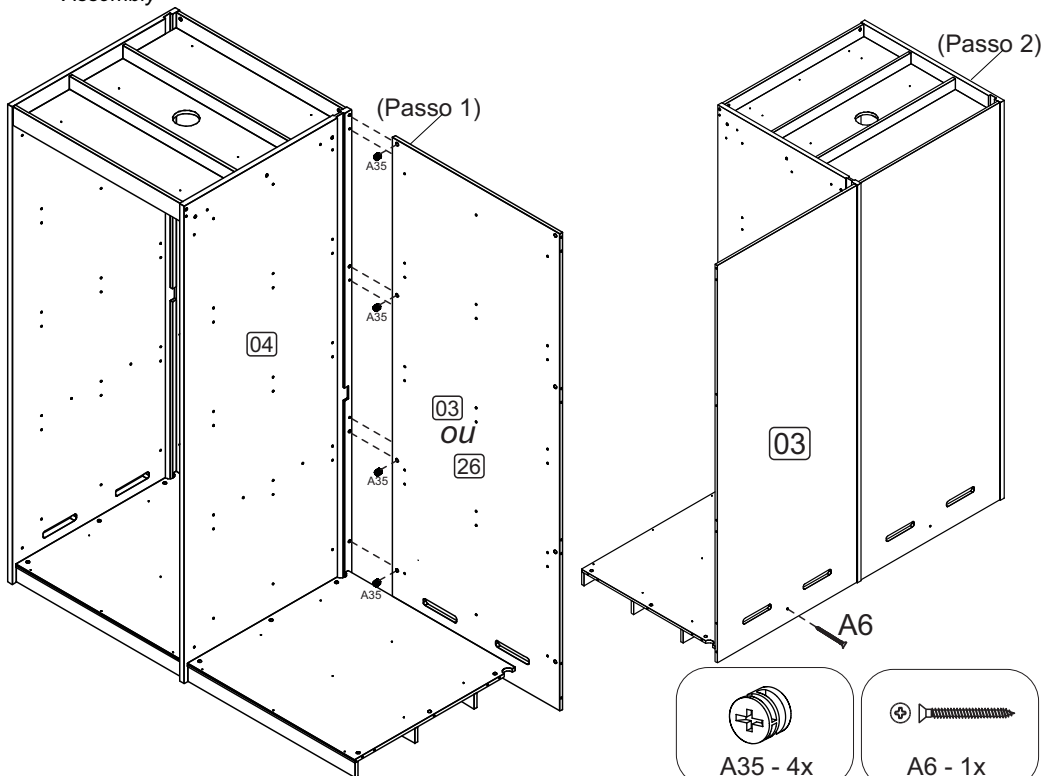

5 MONTAGEM

Armado
Assembly

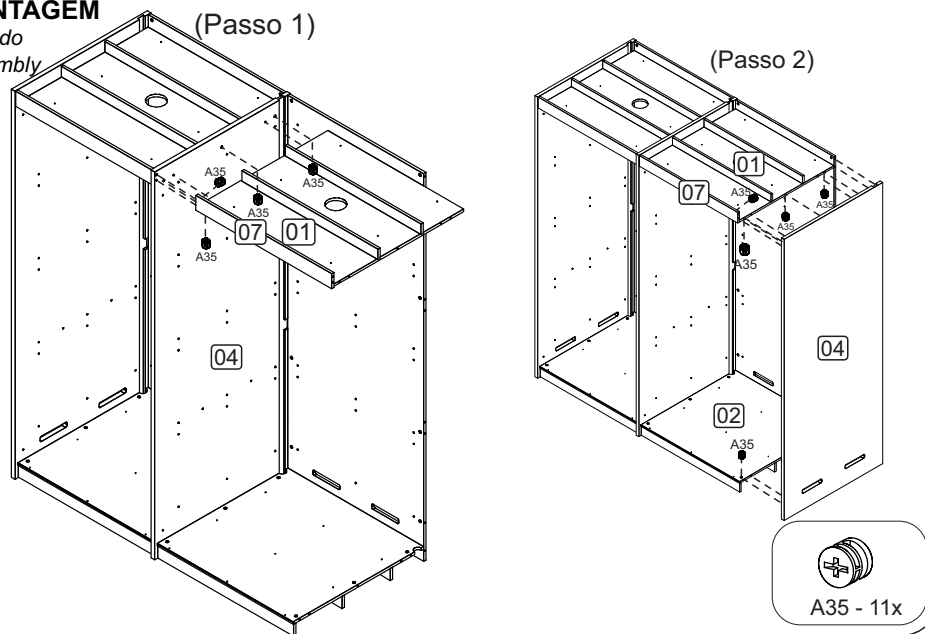

06/12

6

Realizar a instalação da parte elétrica,
antes de fixar as placas estofadas.
Realizar la instalación de la parte eléctrica,
antes de colocar las tablas tapizadas.
Carry out the installation of the electrical part,
before attaching the upholstered boards.

7 MONTAGEM

Armado
Assembly

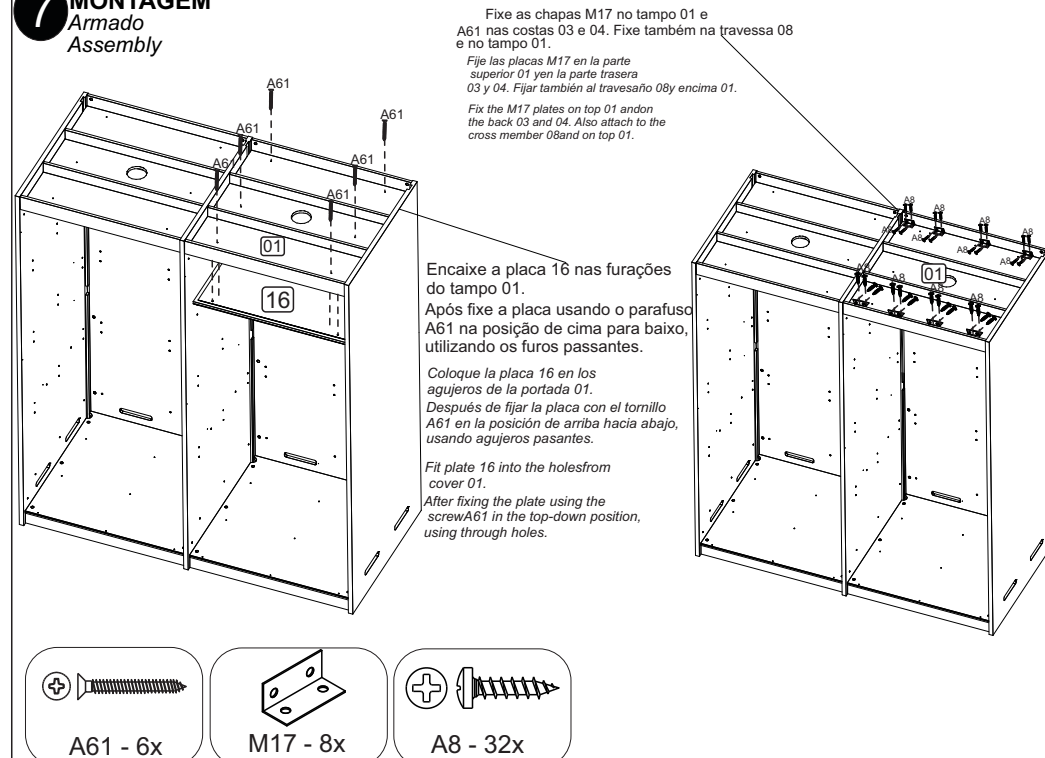

8 MONTAGEM

Armado
Assembly

Posição da mesa lado esquerdo, fixar chapa 14 com recorte para o lado esquerdo.

Posición de la mesalado izquierdo, arreglar placa 14 con recorte al lado izquierdo.

Table position left side, fix plate 14 with cutout to the left side.

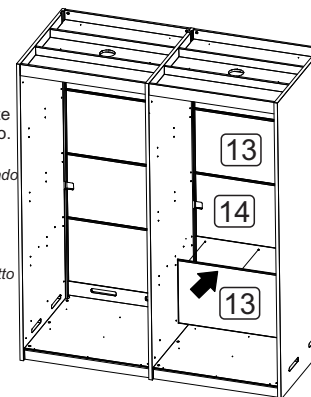

Posição da mesa lado direito, fixar chapa 14 com recorte para o lado direito.

Posición de la mesa lado derecho, arreglar placa 14 con recorte al lado derecho.

Table position right side, fix plate 14 with cutout to the right side.

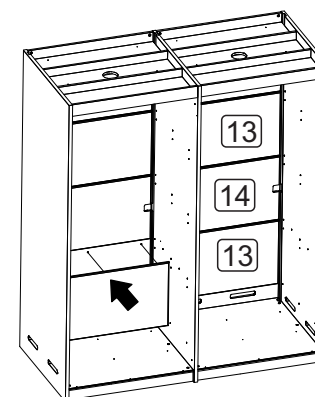

07/12