

#### Manutenção e Limpeza

Vidros: pano levemente umedecido com álcool, seguido de pano seco.  
 Madeiras: pano levemente umedecido com água, seguido de pano seco.  
 \*Nunca utilizar produtos químicos ou abrasivos.

#### Maintenance and Cleaning

Glasses: cloth lightly moistened with alcohol, followed by dry cloth.  
 Woods: cloth slightly moistened with water, followed by cloth seo.  
 \*Never use chemicals or abrasives.

#### Mantenimiento y Limpieza

Vidrios: legeramente humedecido con alcohol, seguido de un paño seco.  
 Madera: ligeramente humedecido con agua, seguido de un paño seco.  
 \*No utilice nunca productos quimicos o abrasivos.

# INSTRUÇÕES DE MONTAGEM ASSEMBLY INSTRUCTIONS INSTRUCCIONES DE MONTAJE

## ARMÁRIO UMA PORTA

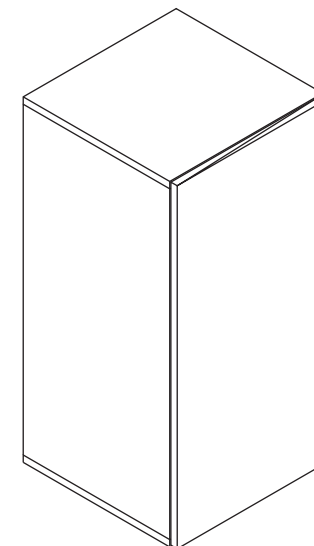

REF. #INF-3674

**GEBB WORK**  
 MOBILIÁRIO PARA ESCRITÓRIO

GEBB Work Ind. de Móveis Ltda.  
 Rua Felix Roman, 190  
 São Valentin

95709-170 - Bento Gonçalves - RS - Brasil  
 Fone: (0XX54) 3454-1105 - (0XX54) 3453-1407  
 Phone: (0XX54) 3454-1105 - (0XX54) 3453-1407

E-mail: [pedidos@gebbwork.com.br](mailto:pedidos@gebbwork.com.br)

[www.gebbwork.com.br](http://www.gebbwork.com.br)

WhatsApp: +55 54 99177-8324

## LISTA DE PEÇAS

01	Tampo/Base	(2x)
02	Lateral	(2x)
03	Costa	(1x)
04	Prateleira	(1x)
05	Porta	(1x)

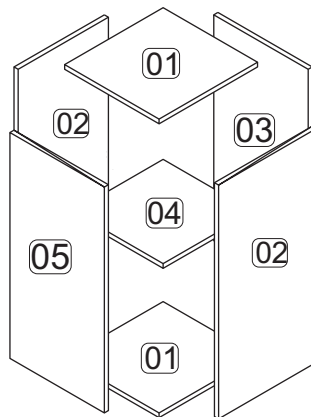

## LIST OF PIECES

## LISTA DE PIEZAS

01 Top/ Base	(2x)	01 Tapa	(2x)
02 Side	(2x)	02 Lateral	(2x)
03 Coast	(1x)	03 Costa	(1x)
04 Shelf	(1x)	04 Estante	(1x)
05 Port	(1x)	05 Puerta	(1x)

## LISTA DE FERRAGENS

A8 - PARAF. 4,0x14 CP  
12x



A14 - PARAF. 4,0x35 CC  
4x

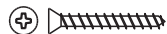

D1 - CAVILHA 8x30  
20x



F1 - TAPA FURO Ø18  
18x



A2 - PARAF. 3,5x14 CC  
4x



A32 - PARAF. MINIFIX  
14x

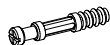

A35 - TAMBOR  
MINIFIX 14x



H15-PULSADOR MAGNETICO  
1x



G3 - DOBRADIÇA 35 C/PISTÃO  
BAIXA + CALÇO 2x



## PASSO 5

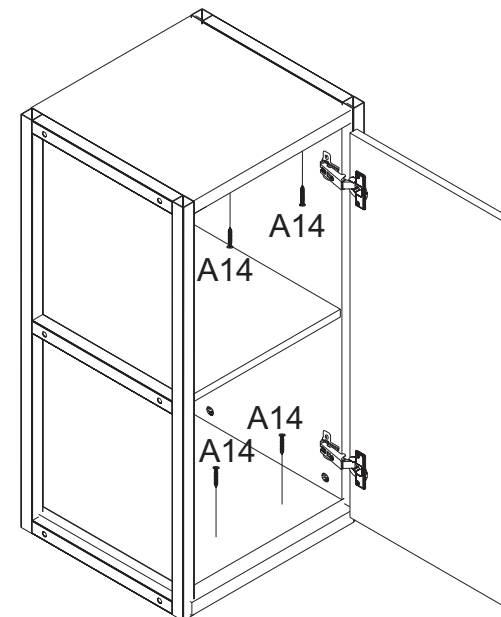

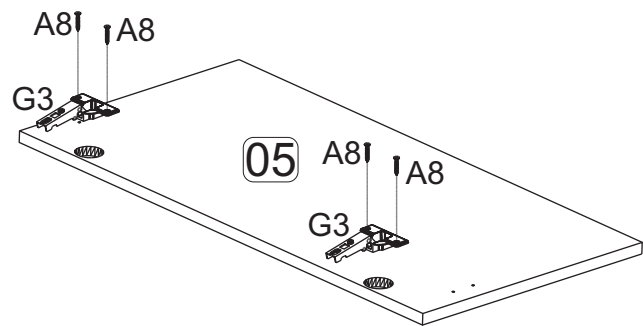
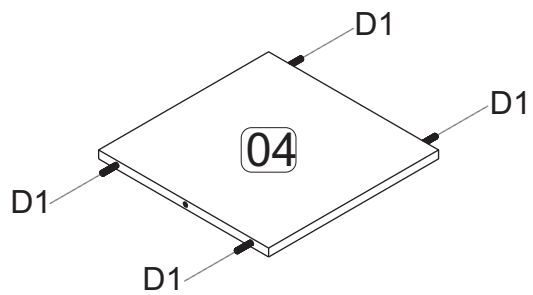
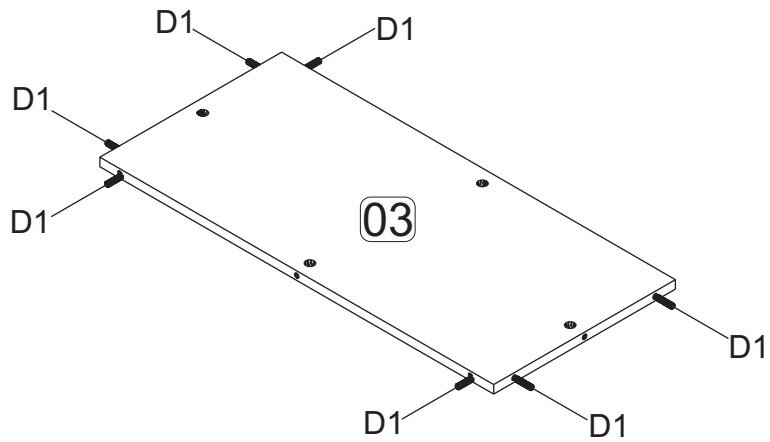

**ETAPA DE MONTAGEM**

**PASSO 1**

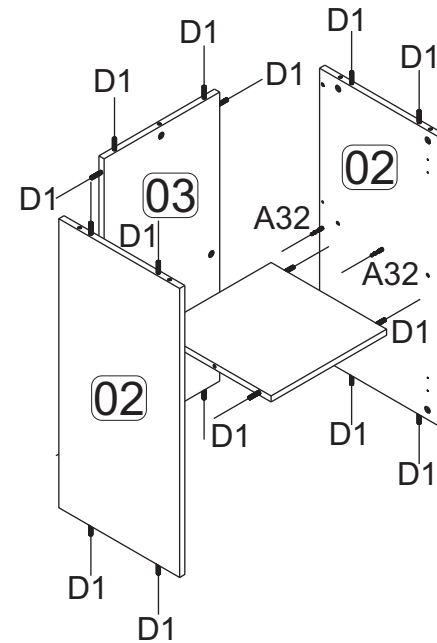

**PASSO 2**

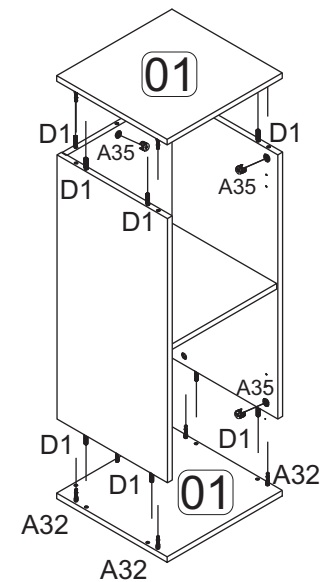

PASSO 3

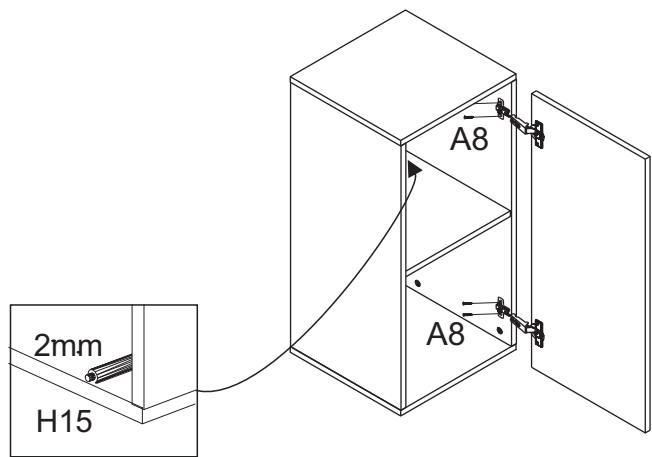

PASSO 4

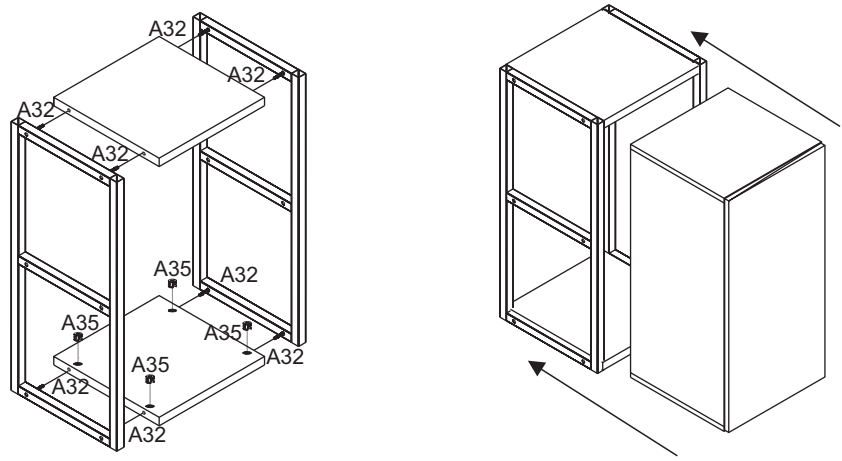

PREPARAÇÃO DAS PEÇAS

